

My50 E

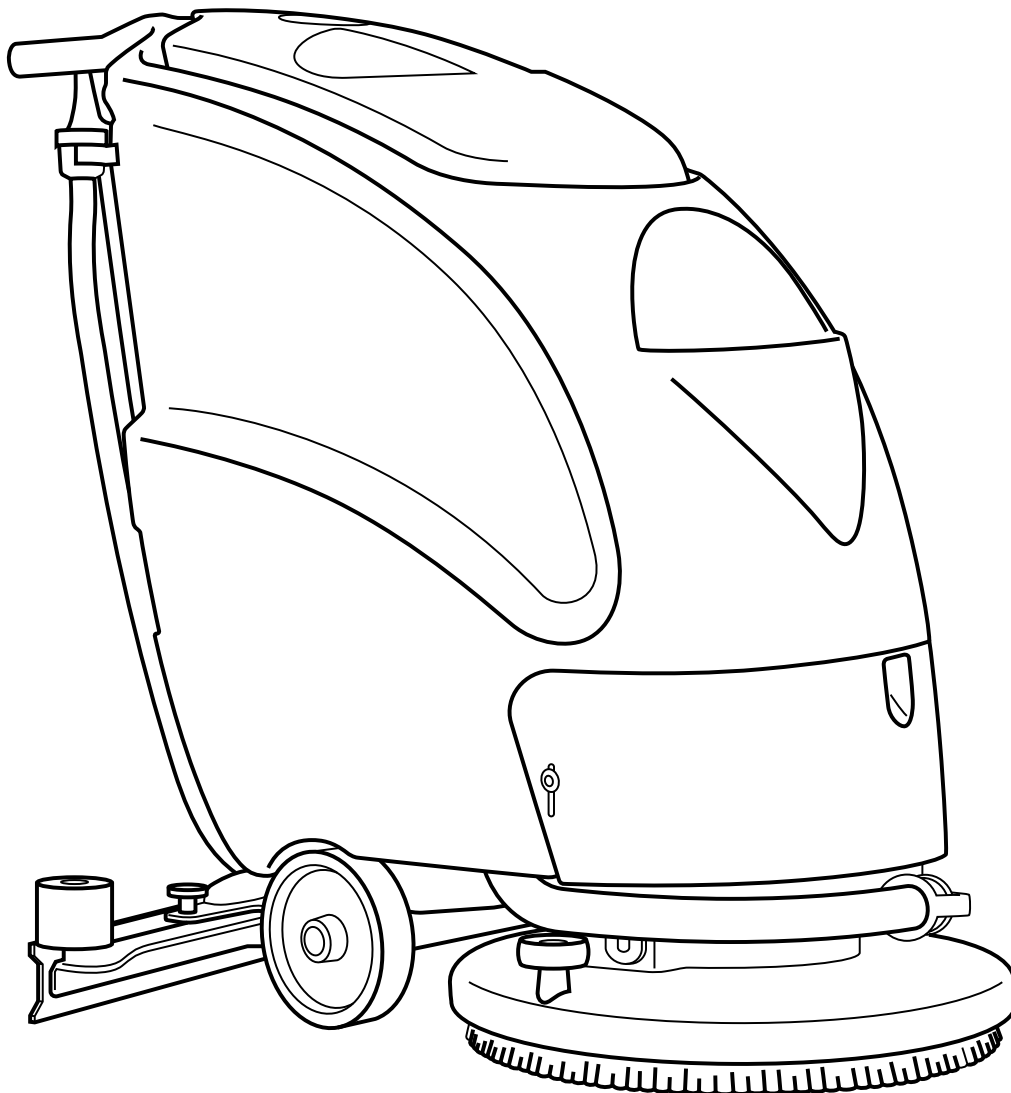

PROFESSIONAL SCRUBBING MACHINES

IT **CATALOGO RICAMBI**
EN **SPARE PARTS CATALOGUE**
FR **CATALOGUE DE PIECES DETACHEES**

DE **ERSATZKATALOG**
ES **CATALOGO PIEZAS DE REPUESTO**

 **FIMAP**[®]



DOC. 10065613 - Ver. AA - 10-2016

SOMMARIO

SOMMARIO	3
GRUPPO BASAMENTO	6
PREMONTAGGIO TERGIPAVIMENTO L=680mm	10
PREMONTAGGIO TERGIPAVIMENTO L=780mm (OPZIONALE)	12
GRUPPO COMANDO TERGIPAVIMENTO	14
GRUPPO SERBATOIO E ACCESSORI	18
GRUPPO IMPIANTO ELETTRICO	22
GRUPPO ETICHETTE	26

SUMMARY

SUMMARY	3
BRUSHES BASE ASSEMBLY	6
SQUEEGEE ASSEMBLY L=680mm	10
SQUEEGEE ASSEMBLY L=780mm (OPTIONAL)	12
SQUEEGEE CONTROL ASSEMBLY	14
TANK & WATER UNIT ASSEMBLY	18
ELECTRIC COMPONENTS ASSEMBLY	22
DECAL ASSEMBLY	26

SOMMAIRE

SOMMAIRE	3
GROUPE PLATEAU DES BROSSES	6
ENSEMBLE DE SUCEUR L=680mm	10
ENSEMBLE DE SUCEUR L=780mm (OPTION)	12
GROUPE COMMANDE DE SUCEUR	14
GROUPE DE RESERVOIRS & HIDRIQUE	18
GROUPE COMPOSANTS ELECTRIQUES	22
GROUPE ETIQUETTE	26

INHALTSANGABE

INHALTSANGABE	3
GRUPPE BÜRSTENGESTELL	6
SAUGFUSSGRUPPE L=680mm	10
SAUGFUSSGRUPPE L=780mm (OPTIONAL)	12
GRUPPE SAUGFUSSBETÄTIGUNG	14
TANK & WASSERGRUPE	18
GRUPPE ELEKTROTEILE	22
SCHILDGRUPPE	26

ÍNDICE

ÍNDICE	3
GRUPO BANCADA CEPILLOS	6
GRUPO LIMPIADOR DE SUELO L=680mm	10
GRUPO LIMPIADOR DE SUELO L=780mm (OPCIONAL)	12
GRUPO MANDO LIMPIAPAVIMENTOS	14
GRUPO TANQUES & AGUA	18
GRUPO COMPONENTES ELECTRICOS	22
GRUPO ETIQUETA	26

IT - Le descrizioni contenute nella presente pubblicazione non si intendono impegnative. L'azienda pertanto, si riserva il diritto di apportare in qualunque momento, le eventuali modifiche ad organi, dettagli, forniture di accessori, che essa ritiene convenienti per un miglioramento o per qualsiasi esigenza di carattere costruttivo o commerciale. La riproduzione anche parziale dei testi e dei disegni, contenuti nella presente pubblicazione, è vietata ai sensi di legge. L'azienda si riserva il diritto di apportare modifiche di carattere tecnico e/o di dotazione. Le immagini sono da intendersi di puro riferimento e non vincolanti in termini di design e dotazione.

INTRODUZIONE:

Il presente vuole essere da guida per l'ordinazione delle parti di ricambio ed è stato realizzato in modo da consentire una rapida identificazione della macchina in tutte le sue versioni e quindi una rapida visualizzazione dei pezzi che la compongono.

MODALITÀ DI ORDINAZIONE:

Per facilitare la ricerca di magazzino e la spedizione dei pezzi di ricambio, si pregano vivamente i Sig. Clienti di attenersi alle seguenti norme e specificare sempre :

Modello e numero di matricola della macchina;
Numero di posizione e numero di tavola dove sono rappresentati;
Codice di ordinazione e denominazione;
Quantità dei pezzi desiderati;
Indirizzo esatto e ragione sociale del Committente, completo con l'eventuale recapito per la consegna della merce;
Mezzo di spedizione desiderato. (Nel caso questa voce non sia specificata la Ditta Costruttrice si riserva di usare a sua discrezione il mezzo più opportuno).

EN - The contained descriptions in the present publication are not binding. The Manufacturer therefore reserves itself the right to bring in whatever moment possible organs changes, details or supplies of accessories, that it holds convenient for an improvement, or for any demand of constructive or commercial character. The partial reproduction of the texts and diagrammes contained in the present catalog, is forbidden by law. The Manufacturer reserves itself the right to bring changes of technical character and/or of endowment. The images are meant of pure reference and not binding in terms of design and endowment.

INTRODUCTION:

This catalogue is intended to serve as a guide for the ordering of spare parts and is designed to facilitate rapid identification of the machine in all its versions and to rapid location of its component parts.

HOW TO ORDER:

For the purpose of simplifying stock searching and the delivery of spare parts, we would ask our customers to observe the following standard procedures, at all times specifying:

The model and part number of the machine;
The position number and the number of the table of chart

in which the parts appear;
Ordering code and part name;
Quantity of parts required;
Precise address and company status of the purchaser placing the order, complete with address for delivery of the goods;
Shipping means required.

FR - Les descriptions contenu dans la présente publication ne s'entendent pas contraignant. Le Fabriquant donc, il se réserve le droit d'apporter dans n'importe quel moment, les modifications éventuelles à organes, détails, fournitures d'accessoires, qu'elle croit convenables pour une amélioration ou pour n'importe quel exigence de caractère constructif ou commercial.

La reproduction partielle aussi des textes et des dessins, contenu dans le présent catalogue, elle est prohibée aux termes de la loi. Le Fabriquant se réserve le droit d'apporter modifications de caractère technique et/ou de dotation. Les images sont à s'entendre en référence pure et pas contraignants en termes de design et dotation.

INTRODUCTION:

Le présent catalogue a pour but de guider l'utilisateur dans les commandes de pièces détachées. Il a été réalisé pour faciliter une identification rapide de la machine dans toutes ses versions et permet ainsi un repérage rapide de ses composants.

COMMENT PASSER COMMANDE:

Afin de simplifier la recherche dans le magasin et l'expédition des pièces de rechange, nous prions notre clientèle de respecter la procédure suivante en indiquant toujours:

Le modèle et numéro de la machine;
Le numéro de la position et numéro du tableau sur lequel figure la pièce;
La référence et la dénomination;
La quantité des pièces demandées;
L'adresse exacte et la raison sociale de l'acheteur qui passe la commande, en indiquant l'adresse de livraison;
Le moyen de transport désiré (dans le cas où ceci n'est pas précisé l'expediteur se réserve le droit de choisir le transporteur).

DE - Die Beschreibungen, welche in der vorliegenden Veröffentlichung vorhanden sind, sind nicht verpflichtend. Die Firma behält sich das Recht vor jederzeit eventuelle Modifikationen an wesentlichen Baugruppen, Details und Zubehör-Teilen durchzuführen, wenn dies für vorteilhaft bewertet wird und zu einer Verbesserung führt oder aufgrund von konstruktiven oder kommerziellen Anforderungen. Die Vervielfältigung, auch wenn es sich nur um Text-Auszügen oder Abbildungen handelt, der vorliegenden Bedienungsanleitung ist entsprechend dem Gesetz untersagt. Die Firma behält sich das Recht vor technische Eigenschaften und Ausstattungen zu modifizieren. Die Abbildungen sind zum Verständnis und dienen als Bezug sind nicht bindend in Bezug auf Design und Ausstattung.

EINLEITUNG:

Der vorliegende Katalog versteht sich als Führer für

Ersatzteile und soll eine rasche Identifikation der Maschine in all ihren Ausführungen ermöglichen und daher ein sofortiges Erkennen der Teile, aus denen sie besteht.

BESTELLVORSCHLAG:

Um ein Auffinden im Lager und den Versand der Ersatzteile zu erleichtern, werden die Kunden ersucht, sich an folgende Normen zu halten und immer folgendes anzugeben:

- Modell- und Gerätenummer;
- Positions- und Tafelnummer, wo sie dargestellt sind;
- Bestellnummer und Handelsbezeichnung;
- Menge der gewünschten Teile;
- Genauere Adresse und Firmennamen des Auftraggebers, gemeinsam der ev. Anschrift für die Zusendung der Ware;
- Die gewünschte Versandart (falls nicht angegeben, behält sich der Lieferant das Recht vor, die günstigste Art zu wählen)

ES - Las descripciones contenidas en la presente publicación no son empeñativas. La Empresa por lo tanto se reserva el derecho de aportar en cualquier momento, eventuales modificaciones a órganos, detalles, suministros de accesorios, que ella crea conveniente para una mejoría o por cualquier exigencia de carácter constructivo o comercial. La reproducción parcial de los textos y los diseños, contenidos en el presente catálogo, está prohibida por la ley. La Empresa se reserva el derecho a aportar modificaciones de carácter técnico e/o de dotación. Las imágenes son de pura referencia y no vinculantes en términos de diseño y dotación.

INTRODUCCIÓN:

Ese catálogo quiere servir como guía para pedir las piezas de repuesto y se ha realizado de manera de consentir una rápida identificación de la máquina en todas sus versiones y por consiguiente una rápida individuación de las piezas que la componen.

MODALIDADES DE LOS PEDIDOS:

Para la búsqueda en el almacén y el envío de las piezas de repuesto, se ruega encarecidamente a los Sres. Clientes de seguir las reglas siguientes y de especificar siempre:

- El modelo y el número de matrícula de la máquina;
- El número de posición y el número de la tabla donde son representadas;
- El código de pedido y la denominación;
- El número de piezas que se desean;
- Las señas exactas y la razón social del Comitente, indicando también las señas eventuales para la entrega de la mercancía;
- El medio de envío que se desea. (En caso de que ese dato no se haya especificado, la Empresa Constructora se reserva el derecho de utilizar a su elección el medio más adecuado.

AGGIORNAMENTI DALLA VERSIONE PRECEDENTE:

- = Documento valido dalla matricola.
- ← = Documento annullato dalla matricola.

UPDATES FROM THE PREVIOUS VERSION:

- = This document is valid since the serial number.
- ← = This document is valid till the serial number.

MISE À JOUR DE LA VERSION PRÉCÉDENTE:

- = Document valable à partir du numéro de série.
- ← = Document annulé par le numéro de série.

UPDATES FROM THE PREVIOUS VERSION:

- = This document is valid since the serial number.
- ← = This document is valid till the serial number.

ACTUALIZACIÓN DE LA VERSIÓN ANTERIOR:

- = Documento válido desde la matrícula n°.
- ← = Documento válido hasta la matrícula n°.

PAG.	N. DOC.	VER.	SERIAL NUMBER

10065421-AA

01-08

CR-01/08 GRUPPO BAS MY50E 2015 230V 50HZ

BRUSHES BASE ASSEMBLY
 GROUPE PLATEAU DES BROSSES
 GRUPPE BURSTENGESTELL
 GRUPO BANCADA CEPILLOS

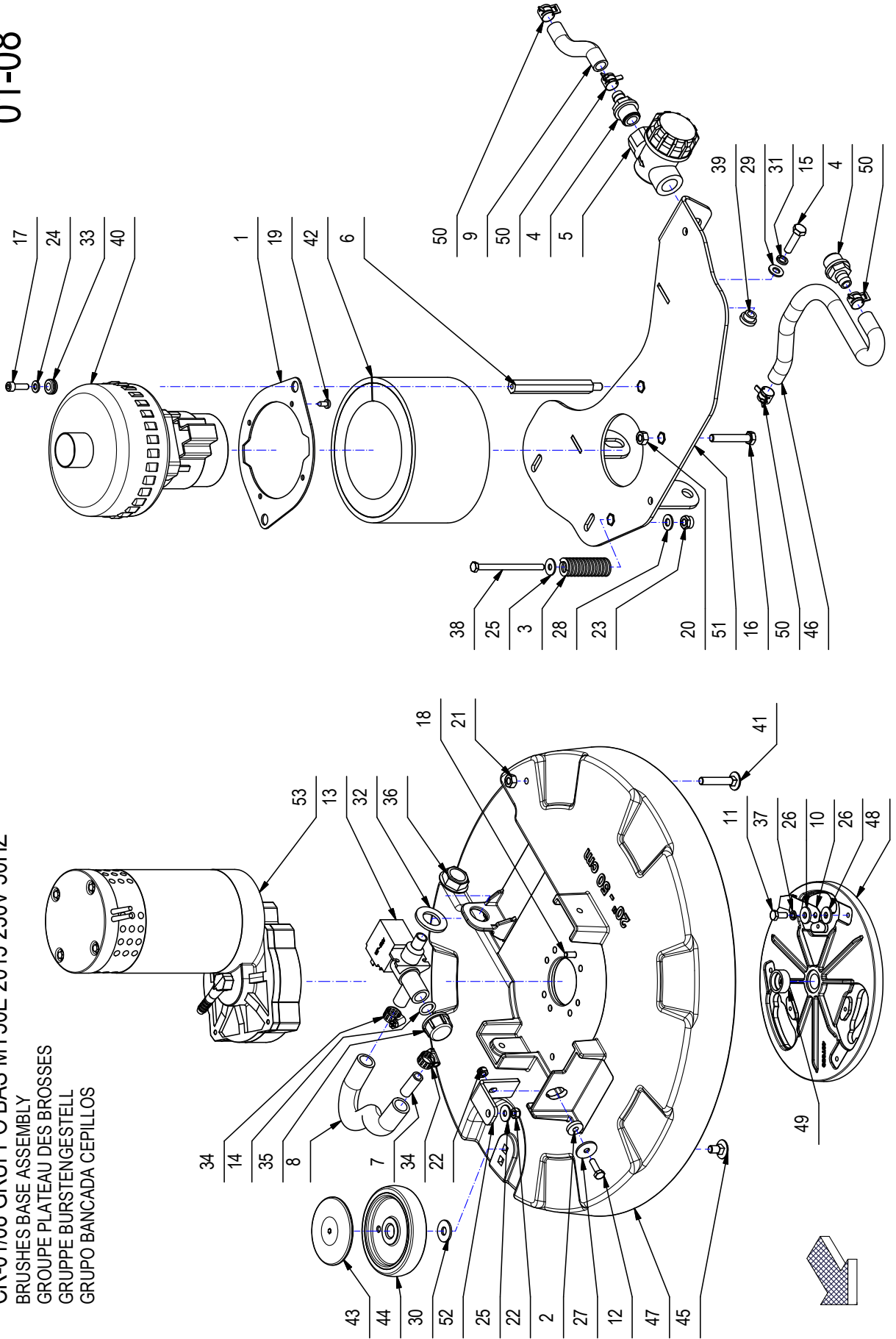

POS	CODICE	QTÀ	DESCRIZIONE	DENOMINATION	DESCRIPTION	BENENNUNG	DESCRIPCION
1	204233	1	PIASTRA MOTORE	PLAQUE	PLAQUE	BEFESTIGUNGSAUFLAGE	PLACA
2	205112	1	DISTANZIALE D=18 d=6.5 S=4 AVP	WASHER	RONDELLE	UNTERLAGSCHEIBE	ARANDELA
3	209845	1	MOLLA COMP. 20x 2x4 x58	SPRING	RESSORT	FEDER	RESORTE
4	210541	2	PORTAGOMMA DIRITTO G 1-2" MASCHIO D=13	CONNECTOR	RACCORD	SCHLAUCHANSCHLUSS	EMPALME TUBO DE GOMA
5	212616	1	FILTRO 1/2" F-F	FILTER ASSEMBLY	FILTRE COMPLET	FILTER KOMPLETT	FILTRO COMPLETO
6	220821	2	PERNO SUPP. MOT. L=120 CH=13 M8/M6 -MY50	PIN	AXE	BOLZEN	PERNO
7	221379	1	TUBO VITREO D=12 d=8 L=30	PIPE	TUBE	ROHR	TUBO
8	223181	1	GUAINA FX15N L=170	PIPE	TUBE	ROHR	TUBO
9	224100	1	TUBO SPIRALATO D=17 d=12 L=90	PIPE	TUBE	ROHR	TUBO
10	407598	1	MOLLA BLOCCAGGIO SPAZZOLE	SPRING	RESSORT	FEDER	RESORTE
11	407662	1	VITE M6x14 TE UNI 5739 A2	SCREW	VIS	SCHRAUBE	TORNILLO
12	407666	1	VITE M6x20 TE UNI 5739 ZINC	SCREW	VIS	SCHRAUBE	TORNILLO
13	407896	1	ELETTROVALVOLA 1/2 230V 14W	SOLENOID VALVE	ELECTROVANNE	MAGNETVENTIL	ELECTROVALVULA
14	408595	1	GUARNIZIONE OR 3056	GASKET	JOINT	DICHTUNG	JUNTA
15	408677	2	VITE M8X30 TE UNI 5739 A2	SCREW	VIS	SCHRAUBE	TORNILLO
16	408692	1	VITE M8X50 TE UNI 5739 ZINC	SCREW	VIS	SCHRAUBE	TORNILLO
17	408796	2	VITE M6x20 TCEI UNI 5931 ZINC	SCREW	VIS	SCHRAUBE	TORNILLO
18	408808	4	VITE M6x16 TCEI UNI 5931 ZINC	SCREW	VIS	SCHRAUBE	TORNILLO
19	408883	4	VITE D.4.8x13 AUTOF. UNI 6954 NICH.	SCREW	VIS	SCHRAUBE	TORNILLO
20	409046	1	DADO M8x6.5 UNI 5588 ZINC	NUT	ECROU	MUTTER	TUERCA
21	409049	1	DADO M8x6.5 UNI5588 A2	NUT	ECROU	MUTTER	TUERCA
22	409082	2	DADO M6x6 AUTOBL UNI 7474 ZINC	LOCK NUT	ECROU AUTOFREINES	SICHERUNGSMUTTER	TUERCA AUTOBLOCANTE
23	409085	3	DADO M8x8.5 AUTOBL. UNI 7474 ZINC	LOCK NUT	ECROU AUTOFREINES	SICHERUNGSMUTTER	TUERCA AUTOBLOCANTE
24	409156	2	ROSETTA 6x12x1.6 UNI 6592 ZINC	WASHER	RONDELLE	UNTERLAGSCHEIBE	ARANDELA
25	409160	2	ROSETTA 6x18x1.5 UNI 6593 ZINC	WASHER	RONDELLE	UNTERLAGSCHEIBE	ARANDELA
26	409161	2	ROSETTA 6.6x18x2 UNI 6593 A2	WASHER	RONDELLE	SCHIBE	ARANDELA
27	409162	1	ROSETTA 6.5x24x2 UNI 6593 ZINC	WASHER	RONDELLE	UNTERLAGSCHEIBE	ARANDELA
28	409175	3	ROSETTA 8x17x1.6 UNI 6592 ZINC.	WASHER	RONDELLE	UNTERLAGSCHEIBE	ARANDELA
29	409177	2	ROSETTA 8x17x1.6 UNI 6592 A2	WASHER	RONDELLE	SCHIBE	ARANDELA
30	409185	1	ROSETTA 9x24x2.5 UNI 6593 A2	WASHER	RONDELLE	UNTERLEGSCHEIBE	ARANDELA
31	409187	2	ROSETTA GROWER 8x13x2.2 A2	WASHER	RONDELLE	UNTERLAGSCHEIBE	ARANDELA
32	409230	1	ROSETTA 21x37x3 UNI 6592 ZINC	WASHER	RONDELLE	UNTERLAGSCHEIBE	ARANDELA
33	409810	2	PASSAFILO DIAM. 8x12x1.5	FAIRLEAD	PASSE-CABLE	KABELDURCHGANG	GUIACABLE
34	410292	2	FASCETTA VITE 11/17 ABA	CLAMP	COLLIER	BRIDE	ABRAZADERA
35	410409	1	TAPPO G1/2" F	PLUG	BOUCHON	DECKEL	ASIENTO

10065421-AA

01-08

CR-01/08 GRUPPO BAS MY50E 2015 230V 50HZ

BRUSHES BASE ASSEMBLY
 GROUPE PLATEAU DES BROSSES
 GRUPPE BURSTENGESTELL
 GRUPO BANCADA CEPILLOS

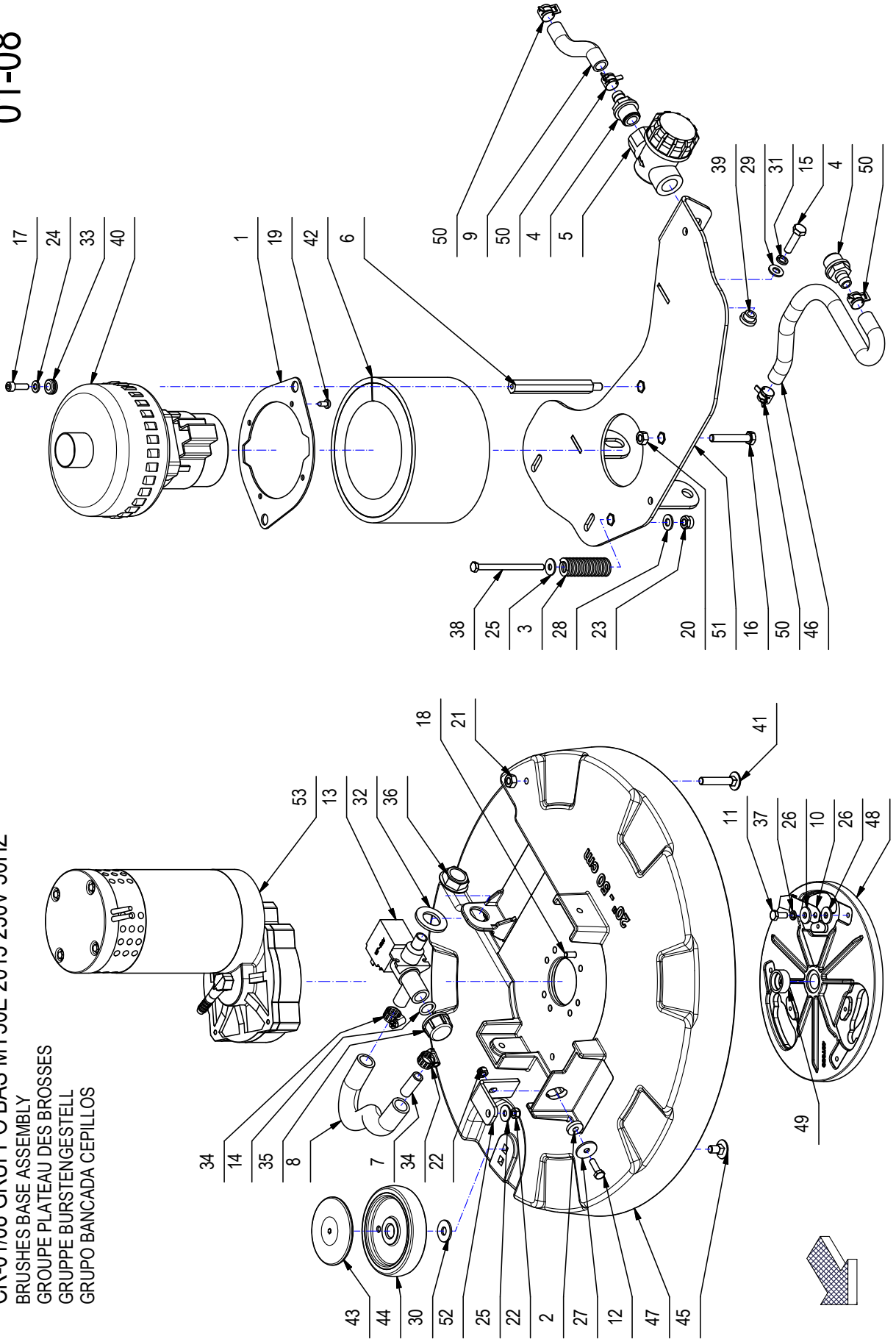

CR-01/08 GRUPPO BAS MY50E 2015 230V 50HZ

01-08

POS	CODICE	QTÀ	DESCRIZIONE	DENOMINATION	DESCRIPTION	BENENNING	DESCRIPCION
36	410442	1	GHIERA 1/2"	RING NUT	EMBOUT	STOPMUTTER	TUERCA ANULAR
37	415945	1	ROSETTA M6 UNI 1751 INOX GROWER	WASHER	RONDELLE	UNTERLAGSCHEIBE	ARANDELA
38	422078	1	VITE M6X90 TE UNI5737 DIN931 ZINC	SCREW	VIS	SCHRAUBE	TORNILLO
39	422120	2	BOCCOLA D=18-13 d=8 S=9,5 OT54	BUSHING	BAGUE	BUCHSE	CASQUILLO
40	427083	1	MOT. ASP. 230V 50Hz 450W H1000 TANG 2S	SUCTION MOTOR	MOTEUR D'ASPIRATION	SAUGMOTOR	MOTOR DE ASPIRACION
41	428807	1	VITE M8x45 TTQST UNI 5732 INOX	SCREW	VIS	SCHRAUBE	TORNILLO
42	433704	1	FONOASSORBENTE SP= 6+20 L=410 H=100	DEADENING	ISOLANT PHONIQUE	SCHALLDICHTUNG	FONOASSORBENTE
43	436119	1	BOCCOLA COPERTURA RUOTINA BASAMENTO MXR	BUSHING	BAGUE	BUCHSE	CASQUILLO
44	436120	1	RUOTINA PARACOLPI BASAMENTO D=100 H=20	BUMPER	BUTEE	PUFFER	PARACHOQUES
45	436341	1	VITE M8x16 TTQST - UNI 5732 - A2	SCREW	VIS	SCHRAUBE	TORNILLO
46	437147	1	TUBO VITREO SPIR. D=17 d=12 L=300	PIPE	TUBE	ROHR	TUBO
47	437855	1	BASAMENTO IMX 50	BRUSH BASE	EMBASE DE BROUSSE	BÜRSTENGESTELL	BANCADA CEPILLO
48	437859	1	FLANGIA SPAZZOLA IMX	FLANGE	FLASQUE	FLANSCH	BRIDA
49	438110	1	DISTANZIALE D=25 d=18,1-20 S=10 AISI 303	SPACER	ENTRETOISE	DISTANZHÜLSE	DISTANCIADOR
50	438261	4	FASCETTA METALLICA FBS 17/12	CLAMP	COLLIER	BRIDE	ABRAZADERA
51	439800	1	STAFFA SUPPORTO BASAMENTO MY50 2014	BRUSH BASE SUPPORT	SUPPORT EMBASE DE BROSSE	HALTERUNG BÜRSTENGESTELL	SOPORTE BANCADA CEPILLO
52	439801	1	STAFFA MOLLA BASAMENTO MY50 2014	SUPPORT	SUPPORT	HALTERUNG	SOPORTE
53	441871	1	MOTORID. 230V-375W 140RPM ALBERO FIL.SX	GEARED MOTOR	MOTO-REDUCTEUR	GETRIEBEMOTOR	MOTORREDUCTOR

CR-03 PREM. TERGIPAVIMENTO L=680

SQUEEGEE ASSEMBLY

ENSEMBLE DE SUCEUR

SAUGFUSSGRUPPE

GRUPO LIMPIADOR DE SUELO

03

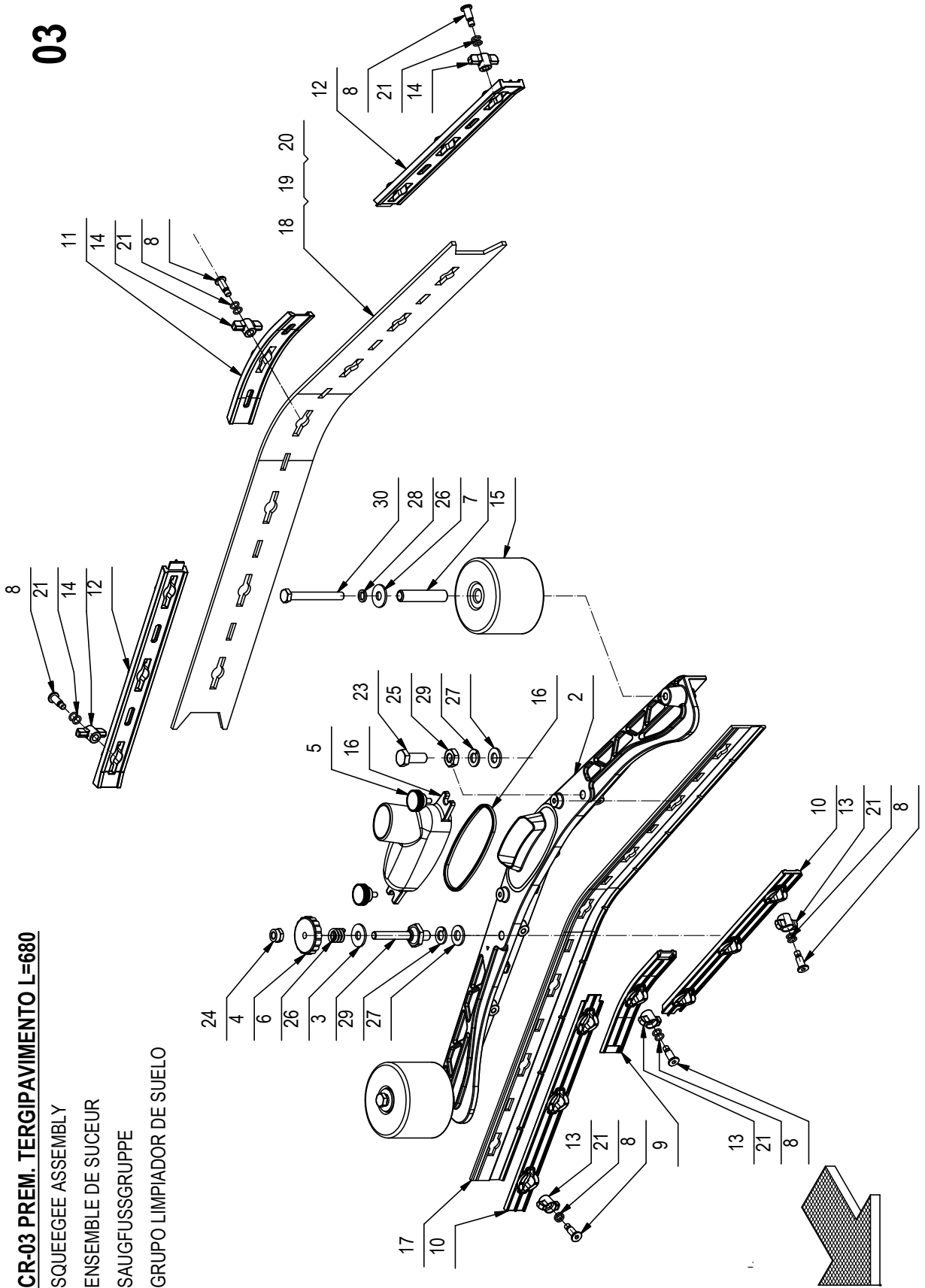

CR-03 PREM. TERGIPAVIMENTO L=680

03

POS.	CODICE	QTÀ	DESCRIZIONE	DENOMINATION	DESCRIPTION	BENENNUNG	DESCRIPCION
1	220615	1	PREM. TERGIPAVIMENTO L=680	SQUEEGEE ASSEMBLY	SUCEUR COMPLETE	SAUGFUSS KOMPLETT	LIMPIAPAVIMENTOS COMPLETO
2	430940	1	CORPO TERGIPAVIMENTO 2010 L=638	SQUEEGEE BODY	CORPS DE SUCEUR	SAUGFUSSKÖRPER	CUERPO LIMPIAPAVIMENTOS
3	219372	1	COLONNETTA SGANCIO M10-CH22 - M8 (28-45)	STUD BOLT	TIGE	GEWINDEBOLZEN	PRISIONERO
4	400112	1	VOLANTINO LOBATO PASSANTE V40/PS M8	HANDWHEEL	VOLANT	HANDGRIFF	RUEDA DE MANIOBRA
5	435330	2	VOLANTINO ZIGRINATO ZPX22 M5x10 6331400	KNOB	POMMEAU	RENDELSCHRAUBE	POMO
6	408098	1	MOLLA COMPR. 14.5x15x2.5 COLON. TERGIP.	SPRING	RESSORT	FEDER	RESSORTE
7	411765	2	BOCCOLA D=12 d=8.2 S=58.5 OT63	BUSHING	BAGUE	BUCHSE	CASQUILLO
8	430903	14	PERNO MANOPOLINA D=11.8 d=7 M=6 H=22	PIN	AXE	BOLZEN	PERNO
9	430944	1	PREMIGOMMA ANTERIORE CENTRALE TERGI 2010	FRONT BLADE	PLAQUETTE AVANT	VORDERER LEISTE	LISTON DELANTERA
10	430945	2	PREMIGOMMA ANTERIORE L=638 TERGI 2010	FRONT BLADE	PLAQUETTE AVANT	VORDERER LEISTE	LISTON DELANTERA
11	430949	1	PREMIGOMMA POSTERIORE CENTRALE TERGI 2010	REAR BLADE	PLAQUETTE ARRIERE	HINTERER LEISTE	LISTON TRASERA
12	430950	2	PREMIGOMMA POSTERIORE L=638 TERGI 2010	REAR BLADE	PLAQUETTE ARRIERE	HINTERER LEISTE	LISTON TRASERA
13	430954	7	GALLETO CHIUSURA ANTERIORE TERGI 2010	WING NUT	PAPILLON	FLÜGELSCHRAUBE	POMO
14	430955	7	GALLETO CHIUSURA POSTERIORE TERGI 2010	WING NUT	PAPILLON	FLÜGELSCHRAUBE	POMO
15	430956	2	RUOTA PARACOLPI D=80 d=12 H=60	BUMPER WHEEL	ROUE BUTEE	PUFFER RAD	RUEDA PARACHOQUES
16	430957	1	BOCCHETTA DRITTA D=40 + GUARN. TERGI 2010	OPENING	BUSE	ÖFFNUNG	BOQUILLA
17	219374	1	GOMMA ANT. POLIURETANO H=45 L=690 S=4	FRONT RUBBER	BAVETTE AVANT	VORDERER SAUGGUMMI	GOMA DELANTERA
18	430968	1	GOMMA POST. POLIURETANO H=70 L=750 S=5	REAR RUBBER	BAVETTE ARRIERE	HINTERER SAUGGUMMI	GOMA TRASERA
19	431024	1	GOMMA POST. 33 SHORE H=70 L=750 S=4	REAR RUBBER	BAVETTE ARRIERE	HINTERER SAUGGUMMI	GOMA TRASERA
20	431026	1	GOMMA POST. LATEX H=70 L=750 S=5	REAR RUBBER	BAVETTE ARRIERE	HINTERER SAUGGUMMI	GOMA TRASERA
21	431633	28	O-RING 7x1.5 NBR 70 SHORE	O-RING	JOINT	O-RING	JUNTA ANULAR
23	408741	1	VITE M10x25 TE UNI 5739 A2	SCREW	VIS	SCHRAUBE	TORNILLO
24	409087	1	DADO M8 AUTOBL. UNI 7474 INOX BASSO	LOCK NUT	ECROU AUTOFREINES	SICHERUNGSMUTTER	TUERCA AUTOBLOCANTE
25	415903	1	DADO M10 UNI 5589 A2	NUT	ECROU	MUTTER	TUERCA
26	409185	3	ROSETTA 9x24x2.5 UNI 6593 A2	WASHER	RONDELLE	UNTERLEGSCHIEBE	ARANDELA
27	409192	2	ROSETTA 10x21x2 UNI 6592 A2	WASHER	RONDELLE	UNTERLEGSCHIEBE	ARANDELA
28	409187	2	ROSETTA GROWER 8x13x2.2 A2	WASHER	RONDELLE	UNTERLEGSCHIEBE	ARANDELA
29	409200	2	ROSETTA GROWER 10x2.5x2.5 A2	LOCK WASHER	RONDELLE FREIN	ZAHNSCHIEBE	ARANDELLA DENTADA
30	408696	2	VITE M8X70 TE INOX UNI 5739.	SCREW	VIS	SCHRAUBE	TORNILLO

03

CR-03 PREM. TERGIPAVIMENTO L=780 (OPZIONALE)

SQUEEGEE ASSEMBLY L=780 (OPTIONAL)

SUCEUR COMPLET L=780 (OPTION)

SAUGFUSS KOMPLETT L=780 (OPTIONAL)

LIMPIAPAVIMENTOS COMPLETO L=780 (OPCIONAL)

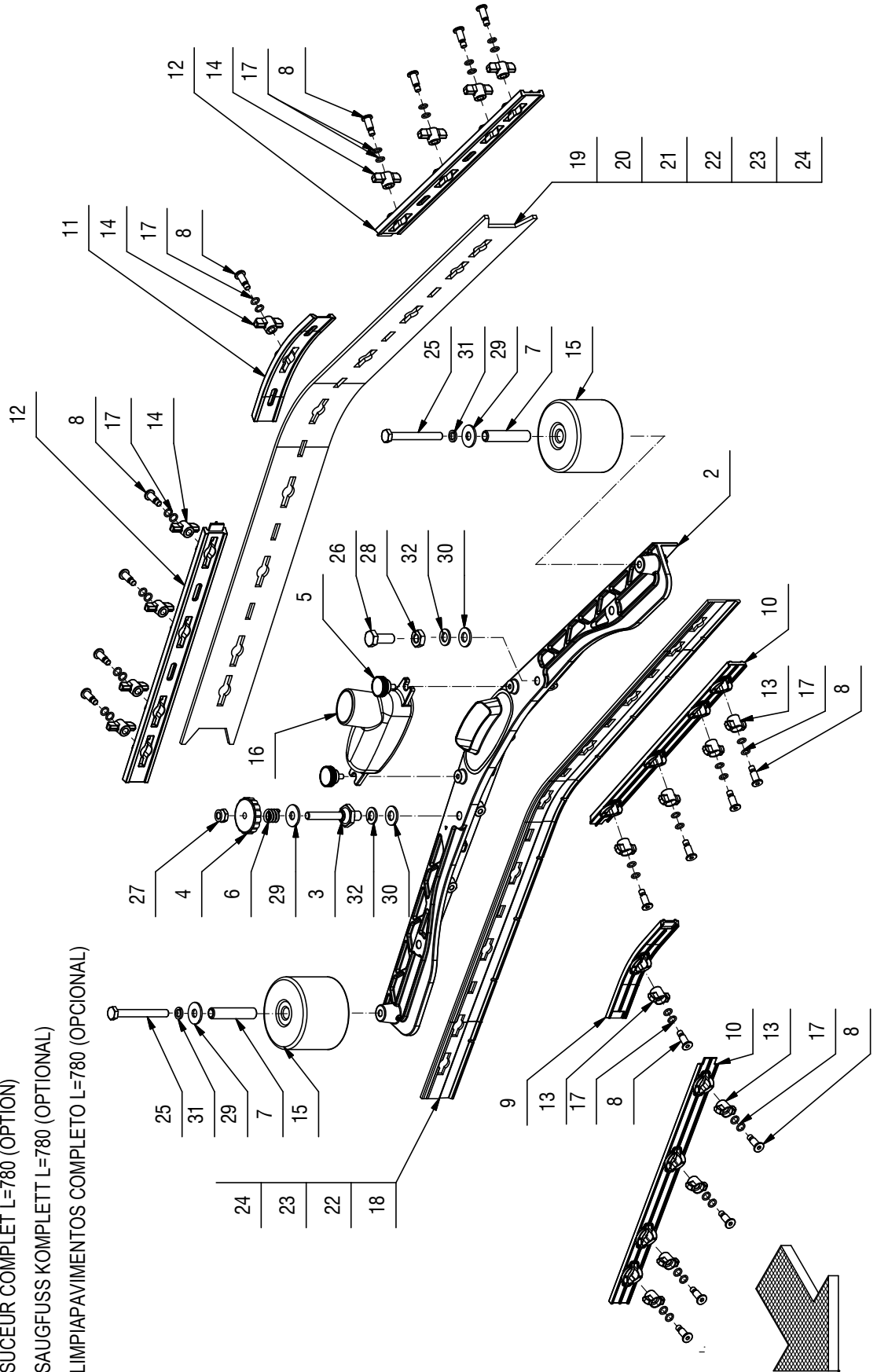

CR-03 PREM. TERGIPAVIMENTO L=780 (OPZIONALE)

03

POS.	CODICE	QTÀ	DESCRIZIONE	DENOMINATION	DESCRIPTION	BENENNUNG	DESCRIPCION
1	220806	1	PREM. TERGIPAVIMENTO L = 780	SQUEEGE ASSEMBLY	SUCER COMPLETE	AUGFUSS KOMPLETT	LIMPIAPAVIMENTOS COMPLETO
2	430941	1	CORPO TERGIPAVIMENTO 2010 L = 736	SQUEEGEE BODY	CORPS DE SUCEUR	SAUGFUSSKÖRPER	CUERPO LIMPIAPAVIMENTOS
3	219372	1	COLONNETTA SGANCIO M10-CH22 - M8 (28-45)	STUD BOLT	TIGE	GEWINDEBOLZEN	PRISIONERO
4	400112	1	VOLANTINO LOBATO PASSANTE V/40/PS M8	HANDWHEEL	VOLANT	HANDGRIFF	RUEDA DE MANIOBRA
5	435330	2	VOLANTINO ZIGRINATO ZPX/22 M5x10 6331400	KNOB	POMMEAU	RENDELSCHRAUBE	POMO
6	408098	1	MOLLA COMPR. 14,5x15x2,5 COLON. TERGIP.	SPRING	RESSORT	FEDER	RESSORTE
7	411765	2	BOCCOLA D=12 d=8,2 S=58,5 OT63	BUSHING	BAGUE	BUCHSE	CASQUILLO
8	430903	18	PERNO MANOPOLINA D=11,8 d=7 M=6 H=22	PIN	AXE	BOLZEN	PERNO
9	430944	1	PREMIGOMMA ANTERIORE CENTRALE TERGI 2010	FRONT BLADE	PLAQUETTE AVANT	VORDERER LEISTE	LISTON DELANTERA
10	430946	2	PREMIGOMMA ANTERIORE L=736 TERGI 2010	FRONT BLADE	PLAQUETTE AVANT	VORDERER LEISTE	LISTON DELANTERA
11	430949	1	PREMIGOMMA POSTERIORE CENTRALE TERGI 2010	REAR BLADE	PLAQUETTE ARRIERE	HINTERER LEISTE	LISTON TRASERA
12	430951	2	PREMIGOMMA POSTERIORE L=736 TERGI 2010	REAR BLADE	PLAQUETTE ARRIERE	HINTERER LEISTE	LISTON TRASERA
13	430954	9	GALLETTO CHIUSURA ANTERIORE TERGI 2010	WING NUT	PAPILLON	FLÜGELSCHRAUBE	POMO
14	430955	9	GALLETTO CHIUSURA POSTERIORE TERGI 2010	WING NUT	PAPILLON	FLÜGELSCHRAUBE	POMO
15	430956	2	RUOTA PARACOLPI D=80 d=12 H=60	BUMPER WHEEL	ROUE BUTEE	PUFFER RAD	RUEDA PARACHOQUES
16	430957	1	BOCCHETTA DRITTA D=40 + GUARN. TERGI2010	OPENING	BUSE	ÖFFNUNG	BOQUILLA
17	431633	36	O-RING 7x1,5 NBR 70 SHORE	O-RING	JOINT	O-RING	JUNTA ANULAR
18	219375	1	GOMMA ANT. POLIURETANO H=45	FRONT RUBBER	BAVETTE AVANT	VORDERER SAUGGUMMI	GOMA DELANTERA
19	434542	1	GOMMA POST. PARA 33SH H=70 SP=4	REAR RUBBER	BAVETTE ARRIERE	HINTERER SAUGGUMMI	GOMA TRASERA
20	434543	1	GOMMA POST. POLIUR. H=70 SP=4	REAR RUBBER	BAVETTE ARRIERE	HINTERER SAUGGUMMI	GOMA TRASERA
21	434544	1	GOMMA POST. LATEX H=70 SP=4	REAR RUBBER	BAVETTE ARRIERE	HINTERER SAUGGUMMI	GOMA TRASERA
22	221391	1	KIT GOMME 33 SHORE L=780 SP=4 (POS. 24+26)	KIT RUBBER	KIT BAVETTE	SAUGGUMMIGRUPPE	KIT GOMA
23	221392	1	KIT GOMME POLIURETANO L=780 SP=4 (POS. 24+25)	KIT RUBBER	KIT BAVETTE	SAUGGUMMIGRUPPE	KIT GOMA
24	221393	1	KIT GOMME LATEX L=780 SP=4 (POS. 24+27)	KIT RUBBER	KIT BAVETTE	SAUGGUMMIGRUPPE	KIT GOMA
25	408696	2	VITE M8X70 TE INOX UNI 5739.	SCREW	VIS	SCHRAUBE	TORNILLO
26	408741	1	VITE M10x25 TE UNI 5739 A2	SCREW	VIS	SCHRAUBE	TORNILLO
27	409087	1	DADO M8 AUTOBL. UNI 7474 INOX BASSO	LOCK NUT	ECROU AUTOFREINES	SICHERUNGSMUTTER	TUERCA AUTOBLOCANTE
28	415903	1	DADO M10 UNI5589 A2	NUT	ECROU	MUTTER	TUERCA
29	409185	3	ROSETTA 9x24x2,5 UNI 6593 A2	WASHER	RONDELLE	UNTERLEGSCHIBE	ARANDELA
30	409192	2	ROSETTA 10x21x2 UNI 6592 A2	WASHER	RONDELLE	UNTERLAGSCHIBE	ARANDELA
31	409187	2	ROSETTA GROWER 8x13x2,2 A2	WASHER	RONDELLE	UNTERLAGSCHIBE	ARANDELA
32	409200	2	ROSETTA GROWER 10x2,5x2,5 A2	LOCK WASHER	RONDELLE FREIN	ZAHNSCHIBE	ARANDELLA DENTADA

04

CR-04 GRUPPO COMANDO TERGIPAVIMENTO

SQUEEGEE CONTROL ASSEMBLY

GROUPE COMMANDE DE SUCEUR

GRUPPE SAUGFUSSBETÄTIGUNG

GRUPO MANDO LIMPIAPAVIMENTOS

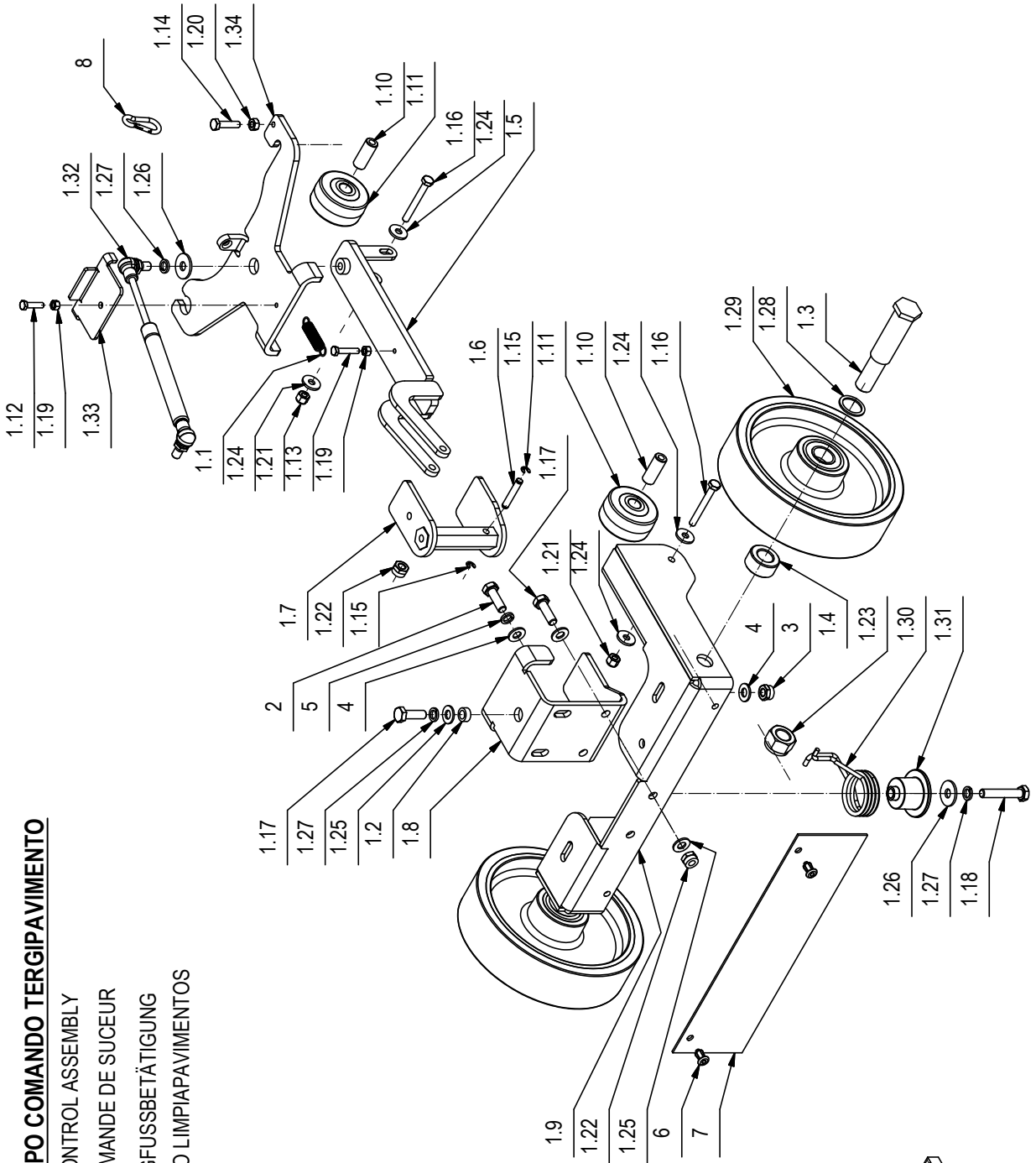

CR-04 GRUPPO COMANDO TERGIPAVIMENTO**04**

POS.	CODICE	QTÀ	DESCRIZIONE	DENOMINATION	DESCRIPTION	BENENNUNG	DESCRIPCION
1	224102	1	PREM. COMANDO TERGI MY50 2014				
1.1	202480	1	MOLLA TRAZ. 10X1,1X46 ZINC	SPRING	RESSORT	FEDER	RESORTE
1.2	210168	1	BOCCOLA D=12,9 d=8,2 S=5,5 OT58	BUSHING	BAGUE	BUCHSE	CASQUILLO
1.3	215023	2	PERNO RUOTE D=20 L=105,5 C40	PIN	AXE	BOLZEN	PERNO
1.4	215032	2	DISTANZIALE D=30 d=16 S=15 AVP	SPACER	ENTRETOISE	DISTANZHUELSE	DISTANCIADOR
1.5	220805	1	BRACCIO ANTERIORE TERGI MY 50	FRONT ARM	BRAS AVANT	VORDERE ARM	BRAZO DELANTERO
1.6	220808	1	PERNO D.6x35 CON SEDI ANELLO	PIN	AXE	BOLZEN	PERNO
1.7	220810	1	PERNO ROTAZIONE TERGI MY 50	PIN	AXE	BOLZEN	PERNO
1.8	220812	1	STAFFA SUPPORTO ATTACCO TERGI MY 50	SUPPORT	SUPPORT	HALTERUNG	SOPORTE
1.9	220814	1	SUPP. RUOTE-ATTACCO TERGI MY 50	SUPPORT	SUPPORT	HALTERUNG	SOPORTE
1.10	400152	2	PERNO D=12 d=6,25 S=30,5 C40	PIN	AXE	BOLZEN	PERNO
1.11	405682	2	RUOTA D=52 d=12,5 S=28 DESMOPAN	IDLE WHEEL	ROUE FOLLE	LOS RAD	RUEDA LIBRE
1.12	407647	1	VITE M5x20 TE UNI 5739 ZINC	SCREW	VIS	SCHRAUBE	TORNILLO
1.13	407651	1	VITE M5x25 TE UNI 5739 DIN 933 (8,8)ZINC	SCREW	VIS	SCHRAUBE	TORNILLO
1.14	407669	1	VITE M6x25 TE UNI 5739 ZINC	SCREW	VIS	SCHRAUBE	TORNILLO
1.15	408367	2	SEEGER RS 4 DIN 6799	SEEGER RING	SERRE CLIPS	SEEGER RINGS	ANILLO SEEGER
1.16	408657	2	VITE M6x50 TE UNI 5739 A2	SCREW	VIS	SCHRAUBE	TORNILLO
1.17	408674	3	VITE M8x25 TE UNI 5739 ZINC	SCREW	VIS	SCHRAUBE	TORNILLO
1.18	408681	1	VITE M8x45 TE UNI 5739 ZINC	SCREW	VIS	SCHRAUBE	TORNILLO
1.19	409036	2	DADO M5x5 UNI 5587 ZINC	NUT	ECROU	MUTTER	TUERCA
1.20	409040	1	DADO M6x5 UNI 5588 ZINC	NUT	ECROU	MUTTER	TUERCA
1.21	409083	2	DADO M6x8 AUTOBL. UNI 7473 DIN 982 A2	NUT	ECROU	MUTTER	TUERCA
1.22	409085	3	DADO M8x8,5 AUTOBL. UNI 7474 ZINC	LOCK NUT	ECROU AUTOFREINES	SICHERUNGSMUTTER	TUERCA AUTOBLOCCANTE
1.23	409097	2	DADO M16x15x1,5 AUTOBL. UNI 7474	LOCK NUT	ECROU AUTOBLOQUANT	STOPMUTTER	TUERCA AUTOBLOCCANTE
1.24	409161	4	ROSETTA 6,6x18x2 UNI 6593 A2	WASHER	RONDELLE	SCHIBE	ARANDELA
1.25	409175	5	ROSETTA 8x17x1,6 UNI 6592 ZINC.	WASHER	RONDELLE	UNTERLAGSCHEIBE	ARANDELA
1.26	409179	2	ROSETTA 9x24x2,5 UNI 6593 ZINC	WASHER	RONDELLE	UNTERLAGSCHEIBE	ARANDELA
1.27	409181	3	ROSETTA GROWER 8x13x2,2 ZINC	LOCK WASHER	RONDELLE FREIN	ZAHNSCHEIBE	ARANDELLA DENTADA
1.28	409228	2	RONDELLA 20x26x1,5 ALLUMINIO	WASHER	RONDELLE	UNTERLAGSCHEIBE	ARANDELA
1.29	420679	2	RUOTA D=172,5 L=45,5 CON CUSCINETTI	WHEEL	ROUE	RAD	RUEDA
1.30	420965	1	MOLLA COMANDO ROTAZIONE TERGI	SPRING	RESSORT	FEDER	RESORTE
1.31	433669	1	BOCCOLA MOLLA EXTRA CORSA TERGI MY 50	BUSHING	BAGUE	BUCHSE	CASQUILLO
1.32	433681	1	MOLLA A GAS CON SNODI ANG. 200N L=274	GAS SHOCK ABSORBER	RESSORT	GASFEDER	AMORTIGUADOR A GAS
1.33	438246	1	STAFFA FINE CORSA MOLLA GAS MY50	SUPPORT	SUPPORT	HALTERUNG	SOPORTE
1.34	439804	1	BRACCIO POSTERIORE TERGI MY50 2014	REAR ARM	BRAS ARRIERE	HINTERER ARM	BRAZO TRASERO
2	408674	2	VITE M8x25 TE UNI 5739 ZINC	SCREW	VIS	SCHRAUBE	TORNILLO
3	409085	3	DADO M8x8,5 AUTOBL. UNI 7474 ZINC	LOCK NUT	ECROU AUTOFREINES	SICHERUNGSMUTTER	TUERCA AUTOBLOCCANTE
4	409175	5	ROSETTA 8x17x1,6 UNI 6592 ZINC.	WASHER	RONDELLE	UNTERLAGSCHEIBE	ARANDELA

04

CR-04 GRUPPO COMANDO TERGIPAVIMENTO

SQUEEGEE CONTROL ASSEMBLY

GROUPE COMMANDE DE SUCEUR

GRUPPE SAUGFUSSBETÄTIGUNG

GRUPO MANDO LIMPIAPAVIMENTOS

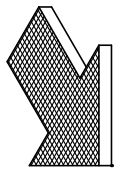
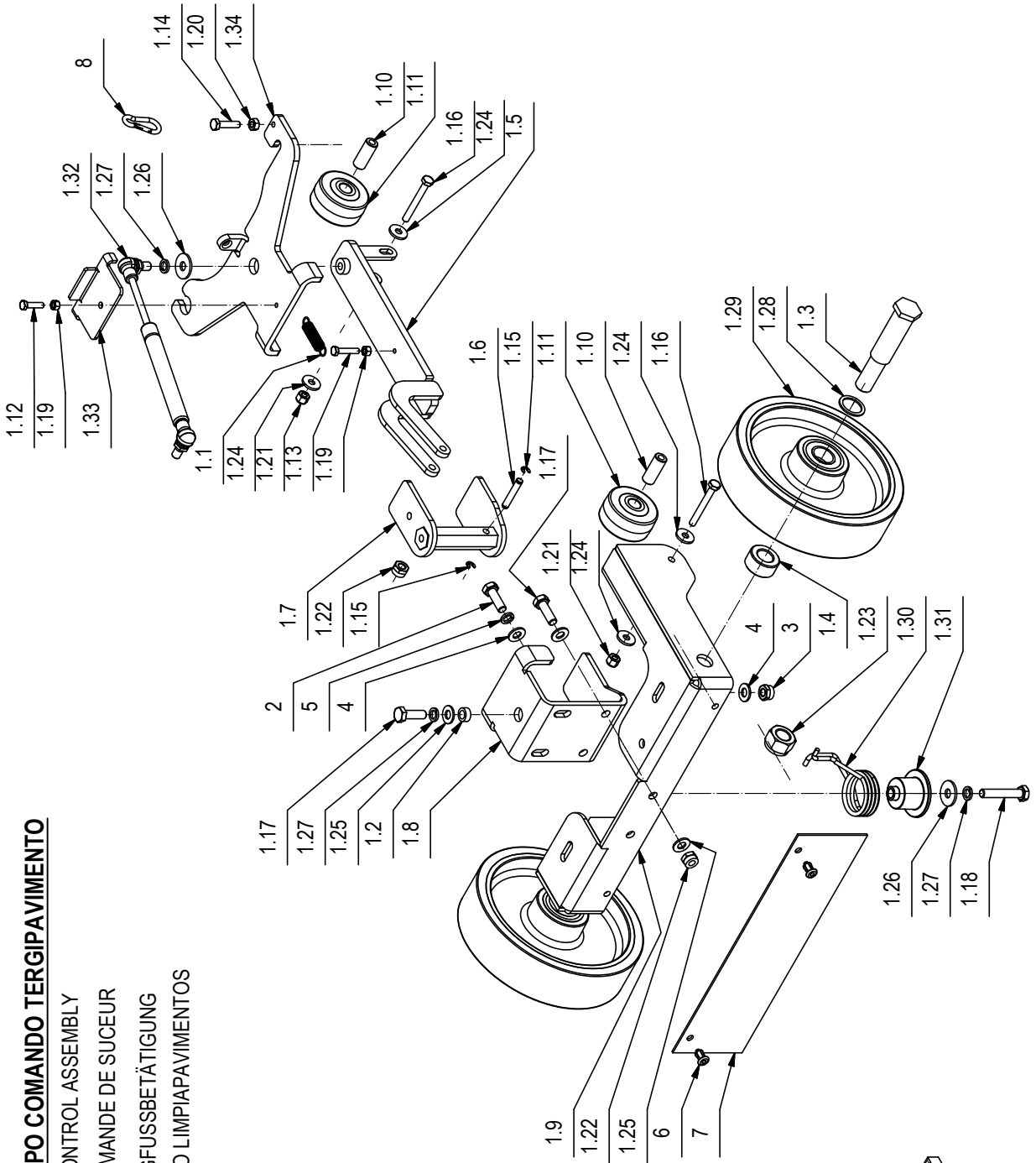

CR-04 GRUPPO COMANDO TERGIPAVIMENTO**04**

POS.	CODICE	QTÀ	DESCRIZIONE	DENOMINATION	DESCRIPTION	BENENNUNG	DESCRIPCION
5	409181	2	ROSETTA GROMER 8x13x2,2 ZINC	LOCK WASHER	RONDELLE FREIN	ZAHNSCHEIBE	ARANDELLA DENTADA
6	415952	2	RIVETTO 6.4X10 NYLON	RIVET	RIVET	NIET	CLAVO
7	433680	1	GOMMA LUBRITENE 290x80x2	RUBBER	BAVETTE	GUMMI	GOMA
8	433682	1	MOSCHETTONE 4x40 ACCIAIO ZINGATO	CARABINIER	MOUSQUETON	KARABINERHAKEN	MOSQUETON

06

CR-06 GRUPPO SERBATOIO E ACCESSORI

TANK & WATER UNIT ASSEMBLY

GROUPE DE RESERVOIRS & HIDRIQUE

TANK & WASSERGRUPE

GRUPO TANQUES & AGUA

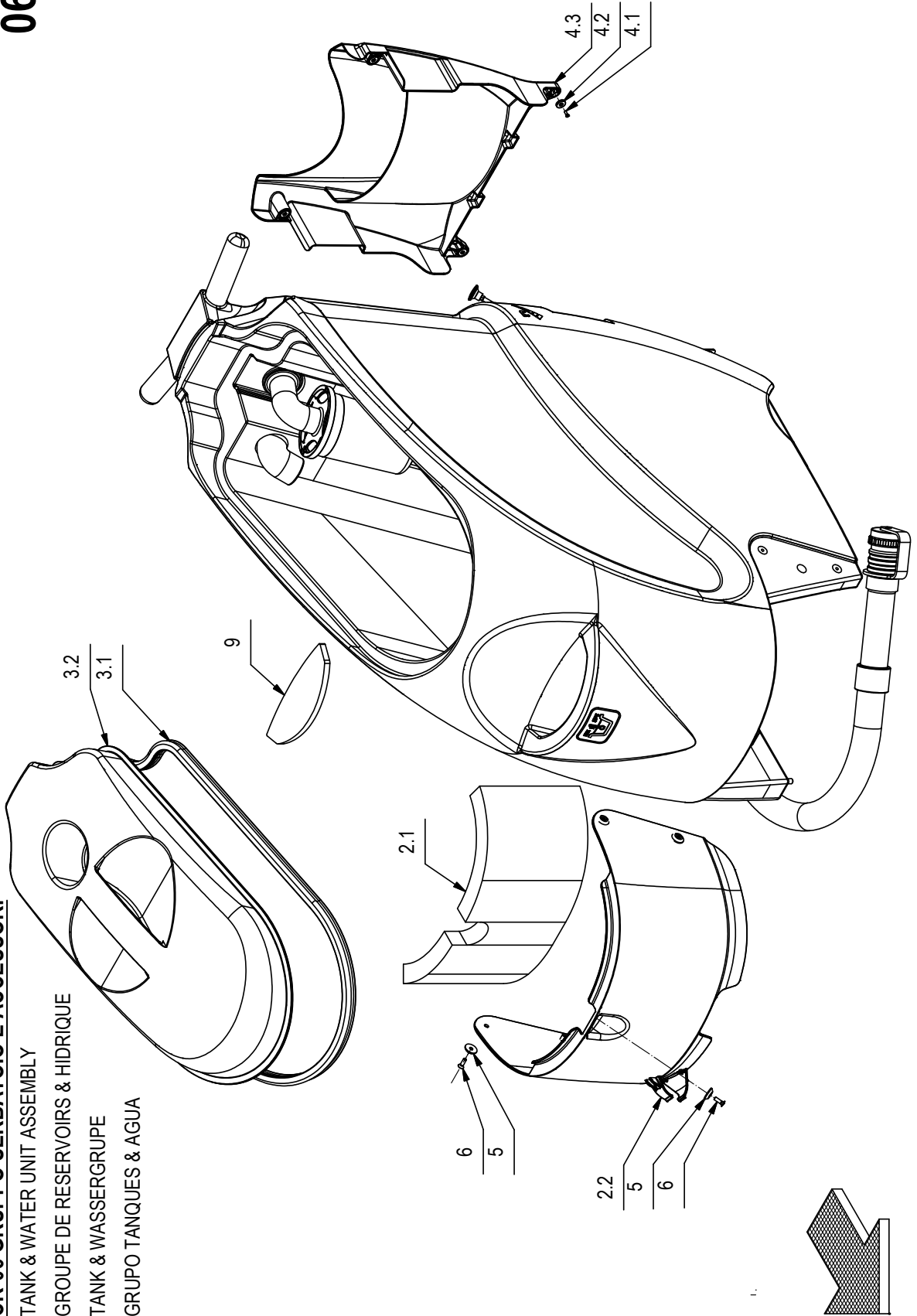

CR-06 GRUPPO SERBATOIO E ACCESSORI**06**

POS.	CODICE	QTÀ	DESCRIZIONE	DENOMINATION	DESCRIPTION	BENENNUNG	DESCRIPCION
1	220792	1	PREM. SERBATOIO MY 50	TANK ASSEMBLY	GROUPE DE RESERVOIR	GRUPE TANK	GRUPO TANQUE
1.1	220786	1	TUBO TRASPARENTE METALFLEX-I D=18 x 780	PIPE	TUBE	ROHR	TUBO
1.2	220789	1	STAFFA GUIDA ASTA RUBINETTO MY 50	SUPPORT	SUPPORT	HALTERUNG	SOPORTE
1.3	220791	1	ASTA RUBINETTO MY 50	ROD	TIGE	STANGE	VARILLA
1.4	222018	1	STAFFA FERMA BATTERIE POSTERIORE MY50	SUPPORT	ATTAQUE	HALTERUNG	SOPORTEFIJADOR
1.5	400854	1	LEVA RUBINETTO CORTA	COCK LEVER	LEVIER DE ROBINET	WASSERHAHNHEBEL	PALANCA DE GRIFO
1.6	405960	2	GUARNIZIONE GOMMA PER RACCORDO 410397	GASKET	JOINT	DICHTUNG	JUNTA
1.7	408854	1	VITE M5X16 TCTC UNI EN ISO 704	SCREW	VIS	SCHRAUBE	TORNILLO
1.8	409034	1	DADO M4x4 UNI 5587 ZINC	NUT	ECROU	MUTTER	TUERCA
1.9	409151	1	ROSETTA 5.5x15x1.5 UNI 6593 ZINC	WASHER	RONDELLE	UNTERLAGSCHEIBE	ARANDELA
1.10	409175	3	ROSETTA 8x17x1.6 UNI 6592 ZINC.	WASHER	RONDELLE	UNTERLAGSCHEIBE	ARANDELA
1.11	409810	1	PASSAFILO DIAM. 8x12x1.5	FAIRLEAD	PASSE-CABLE	KABELDURCHGANG	GUIACABLE
1.12	409819	5	BASETTA TC 142 PER FASCETTE	SUPPORT PLATE	PLAQUE SUPPORT	STÜTZPLATTE	PLACA SOPORTE
1.13	410277	5	FASCETTA PLASTICA 4.5X200	CLAMP	COLLIER	BRIDE	ABRAZADERA
1.14	410280	1	FASCETTA PLASTICA 7.8x240	CLAMP	COLLIER	BRIDE	ABRAZADERA
1.15	410290	1	FASCETTA A VITE 32-44x12.2	CLAMP	COLLIER	BRIDE	ABRAZADERA
1.16	410332	1	CORPO RUBINETTO 3/8 FORO FIL. M5	COCK	ROBINET	WASSERHAHN	GRIFO
1.17	410376	1	PORTAGOMMA DIRITTO 3/8" M D12	CONNECTOR	RACCORD	SCHLAUCHANSCHLUSS	EMPALME TUBO DE GOMA
1.18	410386	1	PORTAGOMMA DIRITTO 1/2" M. D=20	CONNECTOR	RACCORD	SCHLAUCHANSCHLUSS	EMPALME TUBO DE GOMA
1.19	410397	1	RACCORDO PORTAGOMMA DIRITTO D38	FITTING	RACCORD	VERSCHRAUBUNG	RACOR
1.20	410431	1	NIPPOLO MM 3/8"-3/8" OTTONE FILET. CONICO	NIPPLE	RACCORD	NIPPEL	BOQUILLA ROSCADA
1.21	412123	1	CLIP ABS FISSAGGIO TUBO D=38	SPRING	RESSORT	FEDER	RESORTE
1.22	412363	1	ASSIEME FILTRO A CARTUCCIA D=60 H=130	FILTER ASSEMBLY	FILTRE COMPLET	FILTER KOMPLETT	FILTRO COMPLETO
1.23	415637	2	ANELLO EL. RAD. 5 DIN 6799	STOP RING	BAGUE D'ARRET	STOPRING	ANILLO DE PARADA
1.24	415750	3	VITE M5X12 TSP TC UNI 7688 (4.8) ZINC.	SCREW	VIS	SCHRAUBE	TORNILLO
1.25	416172	1	FASCETTA A VITE 15-24 ABA	CLAMP	COLLIER	BRIDE	ABRAZADERA
1.26	416257	1	GHIERA 1" 1/4	RING NUT	EMBOUIT	NUTMUTTER	TUERCA ANULAR
1.27	418311	8	VITE M5x10 TCTC UNI 7687 (4.8) ZINC.	SCREW	VIS	SCHRAUBE	TORNILLO
1.28	424552	1	TUBO D.38X985 SPIRALATO TAPPO INTEGRATO	EXHAUST PIPE	FLEXIBLE DE VIDANGE	ABWASSERSCHLAUCH	TUBO DE DESCARGA
1.29	426339	1	FONOAS. BUGNATO ADES. D.130 H30 - MAXI	DEADENING	ISOLANT PHONIQUE	SCHALLDICHTUNG	FONOABSORBENTE
1.30	426342	1	TAPPO RIEMPIMENTO RAPIDO SOLUZIONE MX	CAP	CAPUCHON	KAPPE	TAPON
1.31	432150	1	TUBO DIAM. 38X1310 SPIRALATO CON GOMITO	SUCTION HOSE	FLEXIBLE ASPIRATION	SAUGSCHLAUCH	TUBO DE ASPIRACION
1.32	433643	1	SERBATOIO MY 50	TANK	RESERVOIR	TANK	TANQUE
1.33	433645	1	POMIELLO GAMMI M4 x Ø26 NERO	KNOB	POMMEAU	RENDELSCHRAUBE	POMO
1.34	433646	1	TUBO SPIRALATO D.38 x 1394 - 2 MANIC.90°	SUCTION HOSE	FLEXIBLE ASPIRATION	SAUGSCHLAUCH	TUBO DE ASPIRACION
1.35	433650	1	RACCORDO RIEMPIMENTO PER TUBO Ø18 - MY50	FITTING	RACCORD	VERSCHRAUBUNG	RACOR
1.36	433651	1	RACCORDO A TACCO GALLEGGIANTE TUBO D.38	FITTING	RACCORD	VERSCHRAUBUNG	RACOR
1.37	433652	1	PROTEZIONE GALLEGGIANTE D.110 x 182 MY50	FLOAT PROTECTION	FLOTTEUR PROTECTION	SCHWIMMERE ABDECKUNG	PROTECCION FLOTADOR

06

CR-06 GRUPPO SERBATOIO E ACCESSORI

TANK & WATER UNIT ASSEMBLY

GROUPE DE RESERVOIRS & HIDRIQUE

TANK & WASSERGRUPE

GRUPO TANQUES & AGUA

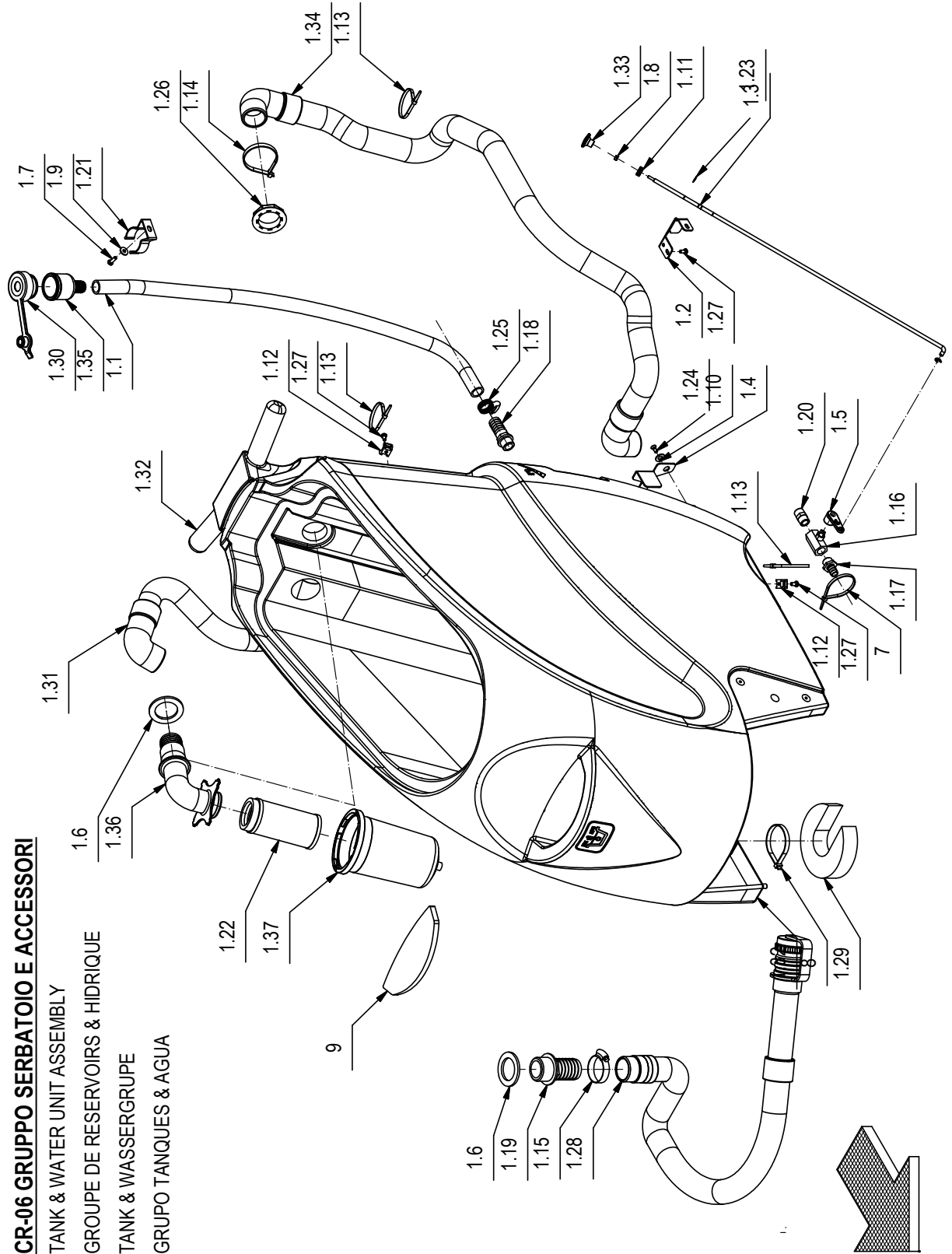

CR-06 GRUPPO SERBATOIO E ACCESSORI**06**

POS.	CODICE	QTÀ	DESCRIZIONE	DENOMINATION	DESCRIPTION	BENENNUNG	DESCRIPCION
2	220797	1	PREM. CARTER ANTERIORE MY 50	COVER	CARTER	ABDECKUNG	CARTER
2.1	433655	1	FONOASSORBENTE BUGNATO ADES. 394x190 H30	DEADENING	ISOLANT PHONIQUE	SCHALLDICHTUNG	FONOASSORBENTE
2.2	433656	1	CARTER ANTERIORE MY 50	COVER	CARTER	ABDECKUNG	CARTER
3	220799	1	PREM. COPERCHIO VANO RECUPERO MY 50	COVER	COUVERCLE	DECKEL	TAPA
3.1	220798	1	GUARNIZIONE COPERCHIO MY 50	PROFILE	PROFIL	PROFIL	PERFIL
3.2	433658	1	COPERCHIO VANO RECUPERO MY 50	COVER	COUVERCLE	DECKEL	TAPA
4	220800	1	PREM. CARTER POSTERIORE BATTERIE MY 50	COVER	CARTER	ABDECKUNG	CARTER
4.1	408922	4	VITE M3x10 TPS UNI 6109 A2	SCREW	VIS	SCHRAUBE	TORNILLO
4.2	430184	4	MAGNETE D15 x d3 x 3 F=3 Kg	MAGNET	AIMANT	MAGNET	IMAN
4.3	433660	1	CARTER POSTERIORE COPRI BATTERIE MY 50	COVER	CARTER	ABDECKUNG	CARTER
5	400250	5	ROSETTA SOTTOVITE D=5X20	SPECIAL WASHER	RONDELLE SPECIALE	UNTERLAGSCHEIBE SPEZIAL	ARANDELA ESPECIAL
6	408516	5	VITE M5x16 TSCTC UNI 7689 ZINC	SCREW	VIS	SCHRAUBE	TORNILLO
7	410277	1	FASCETTA PLASTICA 4.5X200	CLAMP	COLLIER	BRIDE	ABRAZADERA
8	410280	1	FASCETTA PLASTICA 7.8x240	CLAMP	COLLIER	BRIDE	ABRAZADERA
9	433644	1	FILTRO IN STOFFA CARICO SERB. SOL. MY 50	FILTER	FILTRE	FILTER	FILTRO

10065520-AA

10

CR-10 GRUPPO IMPIANTO ELETTRICO 230V 50Hz

ELECTRIC COMPONENTS
 COMPOSANTS ELECTRIQUES
 ELEKTROTEILE
 COMPONENTES ELECTRICOS

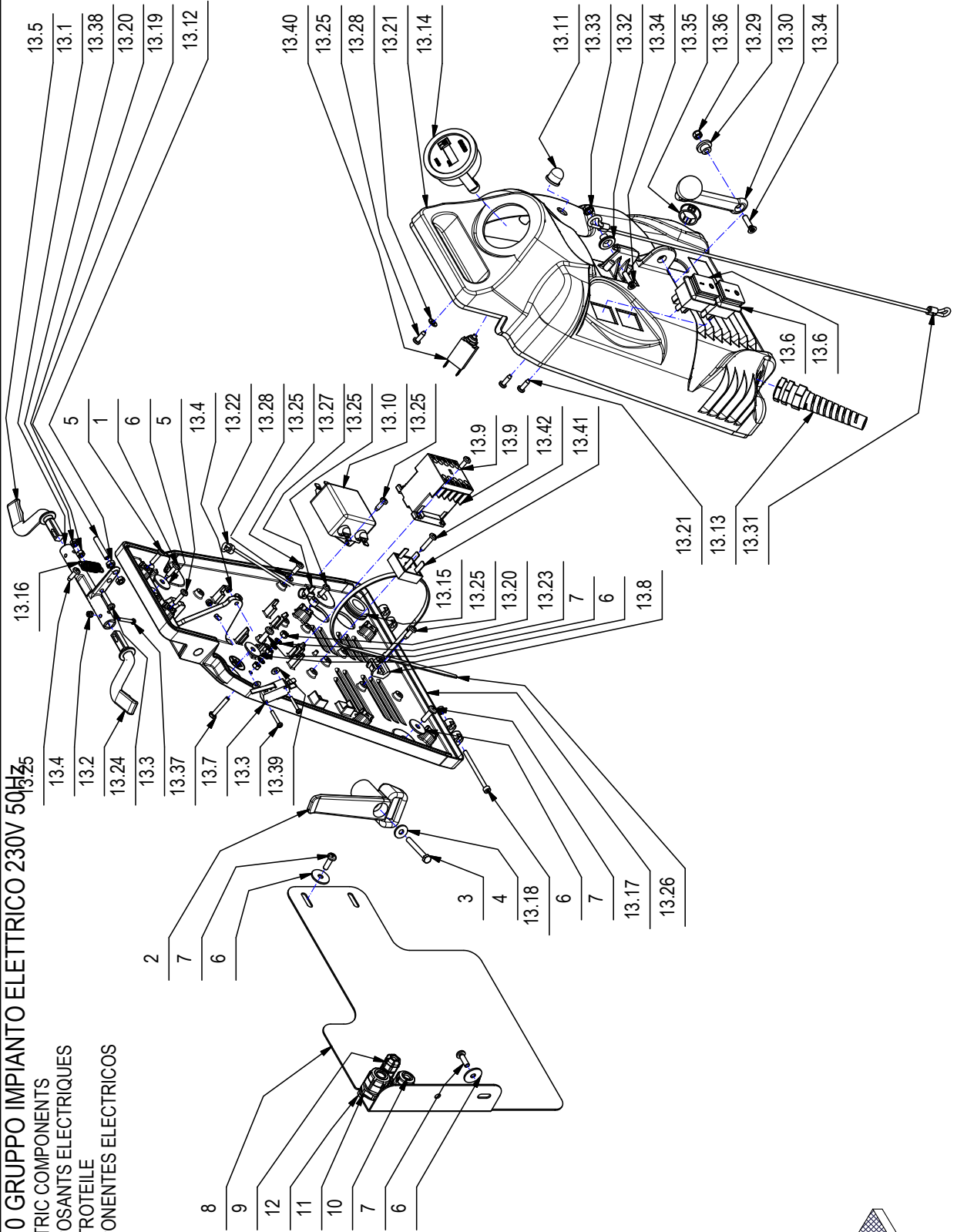

CR-10 GRUPPO IMPIANTO ELETTRICO 230V 50Hz

10

POS	CODICE	QTÀ	DESCRIZIONE	DENOMINATION	DESCRIPTION	BENENNUNG	DESCRIPCION
1	408881	1	VITE D.4.2x16 AUTOF. UNI 6954	SCREW	VIS	SCHRAUBE	TORNILLO
2	416543	1	MANIGLIA PORTACAVO	SUPPORT	SUPPORT	HALTERUNG	SOPORTE
3	407649	1	VITE M5X40 TE UNI 5739 (8.8) ZINC.	SCREW	VIS	SCHRAUBE	TORNILLO
4	409151	1	ROSETTA 5.5x15x1.5 UNI 6593 ZINC	WASHER	RONDELLE	UNTERLAGSCHEIBE	ARANDELA
5	408846	2	VITE M4X16 TCTC UNI 7687 ZINC	SCREW	VIS	SCHRAUBE	TORNILLO
6	417989	9	RONDELLA 5.5x20x1.5 ZNT DIN 9021	WASHER	RONDELLE	UNTERLAGSCHEIBE	ARANDELA
7	408854	8	VITE M5X16 TCTC UNI EN ISO 704	SCREW	VIS	SCHRAUBE	TORNILLO
8	222022	1	STAFFA PROTEZIONE MOTORI MY50 E	SUPPORT	ATTAQUE	HALTERUNG	SOPORTE FIJADOR
9	417841	1	PG7 PASSACAVO + GHIERA	FAIR-LEAD+NUT	PRESSE-ETOUPE+ECROU	KABELVERSCHRAUBUNG+M UT	RACOR CABLE+TUERCA
10	409764	1	PG9+DADO				
11	423190	1	PRESSACAVO PG 11	FAIR-LEAD	PRESSE-ETOUPE	KABELVERSCHRAUBUNG	RACOR CABLE
12	423191	1	DADO X PRESSACAVO PG 11	NUT	ECROU	MUT	TUERCA
13	226135	1	PREM. IMP.ELETT. MY 50E 2015 230V 50Hz	ELECTRIC COMPONENTS	COMPOSANTS ELECTRIQUES	ELEKTROTEILE	COMPONENTES ELECTRICOS
13.1	426351	1	CAMMA COMANDO MARCIA MMX-MX-SMX	CAM	CAME	NOCKEN	LEVA
13.2	426344	1	LEVA COMANDO MARCIA SX MMX-MX-SMX	LEVER	LEVIER	HEBEL	PALANCA
13.3	408834	4	VITE M3X20 TCTC UNI 7687 ZINC	SCREW	VIS	SCHRAUBE	TORNILLO
13.4	409077	4	DADO M3x4.5 AUTOBL. UNI 7474 ZINC	LOCK NUT	ECROU AUTOFREINES	SICHERUNGSMUTTER	TUERCA AUTOBLOCANTE
13.5	426345	1	LEVA COMANDO MARCIA DX MMX-MX-SMX	LEVER	LEVIER	HEBEL	PALANCA
13.6	417622	2	INTERRUTTORE BIPOLARE NERO A SOFFIETTO	BLACK BIPOLAR SWITCH	INTERRUPTEUR	SCHALTER	INTERRUPTOR
13.7	409499	1	MICRO 16A 3x22 LEVA CORTA	MICROSWITCH	MICROINTERRUPTEUR	MIKROSCHALTER	MICROINTERRUPTOR
13.8	409819	4	BASETTA TC 142 PER FASCETTE	SUPPORT PLATE	PLAQUE SUPPORT	STÜTZPLATTE	PLACA SOPORTE
13.9	407849	1	TELERUTTORE 220V 50-60Hz QUAD.	REMOTE CONTROL SWITCH	TELERUPTEUR	SCHÜTZ	TELERRUPTOR
13.10	421110	1	FILTRO ELETTRICO 10SS4-2DC1	FILTER	FILTRE	FILTER	FILTRO
13.11	416817	1	CAPPUCCIO DISGIUNTORE	PROTECTION CAP	CALOTTE DE PROTECTION	SICHERHEITSKAPPE	CAPUCHO DE PROTECCION
13.12	409038	2	DADO M5x3.5 UNI 5589 ZINC	LOCK NUT	ECROU AUTOFREINES	SICHERUNGSMUTTER	TUERCA AUTOBLOCANTE
13.13	409757	1	PRESSACAVO PG13.5 CON GUIDA CAVO E DADO	FAIR-LEAD	PRESSE-ETOUPE	KABELVERSCHRAUBUNG	RACOR CABLE
13.14	427958	1	CONTAORE CURTIS 100-230V AC	HOUR METER	COMPTEUR HORAIRE	BETRIEBSSTUNDENZÄHLER	CUENTAHORAS
13.15	409809	2	PASSACAVO PER FORO D.25 DI=15	FAIRLEAD	PASSE-CABLE	KABELDURCHGANG	GUIACABLE
13.16	408121	1	MOLLA TRAZ. 10x1.1x38 A2	SPRING	RESSORT	FEDER	RESORTE
13.17	433725	1	CRUSCOTTO INTERNO MY 50	INNER INSTRUMENT BOARD	TABLEAU DE BORD INTERIEUR	ARMATURENBRETT INNEN	TABLERO DE INSTRUMENTOS INT.
13.18	433724	2	VITE M4x55 TCEI UNI 5931 8.8 ZINC	SCREW	VIS	SCHRAUBE	TORNILLO
13.19	415811	1	GRANO M5x30 UNI 5925 PIANO	DOWEL	VIS CYLINDRIQUE	MADENSCHRAUBE	TORNILLO
13.20	409034	4	DADO M4x4 UNI 5587 ZINC	NUT	ECROU	MUTTER	TUERCA

10065520-AA

10

CR-10 GRUPPO IMPIANTO ELETTRICO 230V 50Hz

ELECTRIC COMPONENTS
 COMPOSANTS ELECTRIQUES
 ELEKTROTEILE
 COMPONENTES ELECTRICOS

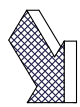
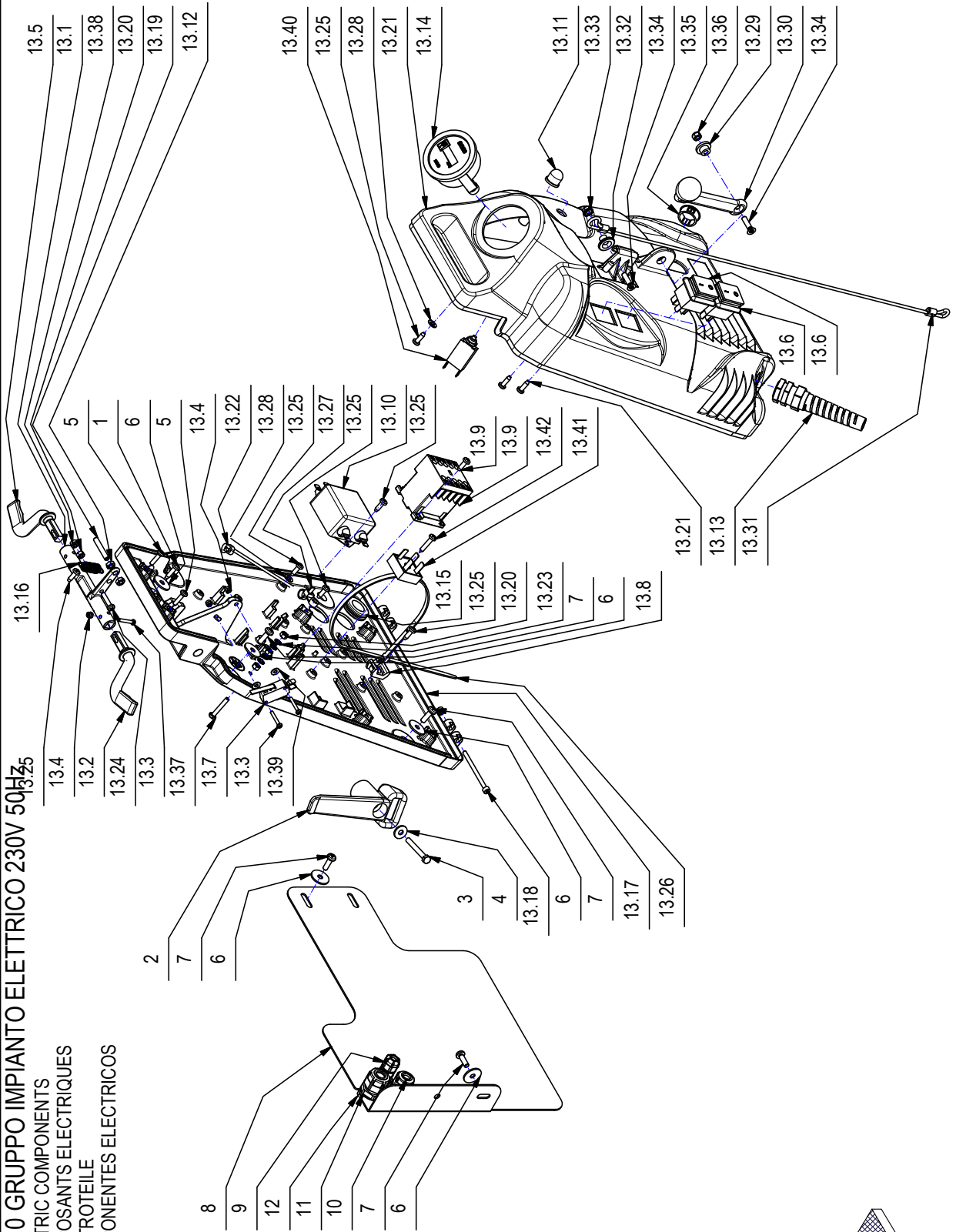

CR-10 GRUPPO IMPIANTO ELETTRICO 230V 50HZ

10

POS	CODICE	QTÀ	DESCRIZIONE	DENOMINATION	DESCRIPTION	BENENNING	DESCRIPCION
13.21	433727	1	CRUSCOTTO ESTERNO MY 50	INSTRUMENT BOARD	TABEAU DE BORD	ARMATURENBRETT	TABLERO DE INSTRUMENTOS
13.22	220838	1	FUNE TRECCIA POLYESTER F.16 D=3 x 400	CABLE	CABLE	KABEL	CUERDA
13.23	409333	4	ROSETTA DENT. EST. D.4 DIN 6798-A	WASHER	RONDELLE	UNTERLAGSCHEIBE	ARANDELA
13.24	415782	1	VITE M4X20 TCTC UNI 7687 ZINC	SCREW	VIS	SCHRAUBE	TORNILLO
13.25	408880	13	VITE D.4.2x13 AUTOF. UNI 10227 X PLASTICA	SCREW	VIS	SCHRAUBE	TORNILLO
13.26	410276	2	FASCETTA PLASTICA 4.5X360	CLAMP	COLLIER	BRIDE	ABRAZADERA
13.27	416828	1	FASCETTA PL.4.8X200 - OCC.D.5 RUFFO	CLAMP	COLLIER	BRIDE	ABRAZADERA
13.28	409150	2	ROSETTA 5X11X1 UNI 6592 ZINC	WASHER	RONDELLE	UNTERLAGSCHEIBE	ARANDELA
13.29	414707	1	BOCCOLA D=16-10 d=5 S=8 OT58	BUSHING	BAGUE	BUCHSE	CASQUILLO
13.30	423323	1	LEVA COMANDO TERGI. VISPA/GENIE	LEVER	LEVIER	HEBEL	PALANCA
13.31	221594	1	FUNE TRECCIA POLYESTER F.16 D=3 x 538	CABLE	CABLE	KABEL	CUERDA
13.32	221578	1	BOCCOLA D=18-8 d=5,2 S=10,5	BUSHING	BAGUE	BUCHSE	CASQUILLO
13.33	409124	1	DADO M5 SERPRESS	NUT	ECROU	MUTTER	TUERCA
13.34	408892	2	VITE M5X20 TSCTC UNI 7689 ZINC	SCREW	VIS	SCHRAUBE	TORNILLO
13.35	409829	1	TAPPO A SCATTO D.20,6 HEYCO	COVER	COUVERCLE	DECKEL	TAPA
13.36	416781	1	DADO M5X5 AUTOBL. UNI 7473 ZINC	LOCK NUT	ECROU AUTOFREINES	SICHERUNGSMUTTER	TUERCA AUTOBLOCANTE
13.37	408635	1	VITE M4X25 TE UNI 5739 ZINC	SCREW	VIS	SCHRAUBE	TORNILLO
13.38	415898	3	DADO M4 AUTOBL UNI7474	LOCK NUT	ECROU AUTOBLOQUANT	STOPMUTTER	TUERCA AUTOBLOCANTE
13.39	409142	2	ROSETTA 4x9x0,8 UNI 6592 ZINC	WASHER	RONDELLE	UNTERLAGSCHEIBE	ARANDELA
13.40	409511	1	DISGIUNTORE DI SICUREZZA 3.5A	CONTACT BREAKER	DISJONCTEUR	AUFTRENNER	DISYUNTOR MECANICO
13.41	416815	1	PONTE DIODO MOTORE 1500 UHS	DIODE	DIODE	DIODE	DIODO
13.42	408878	1	VITE D.4.2x22 AUTOF. NICH UNI 6954	VIS	SCREW	SCHRAUBE	TORNILLO
13.43	444699	1	KIT CAVI MY 50E 2015	CABLE	CABLE	KABEL	CABLE

CR-12 GRUPPO ETICHETTE MY50 E

DECAL ASSEMBLY
 GROUPE ETIQUETTE
 SCHILDGRUPPE
 GRUPO ETIQUETA

1/h	A	36	B	60	C	108
Autonomia h	1,1		0,66		0,37	
Autonomie h	1,1		0,66		0,37	
Autonomia h	1,1		0,66		0,37	

Pericle acqua
 Water flow
 Caudal de agua
 Wasserverbrauch

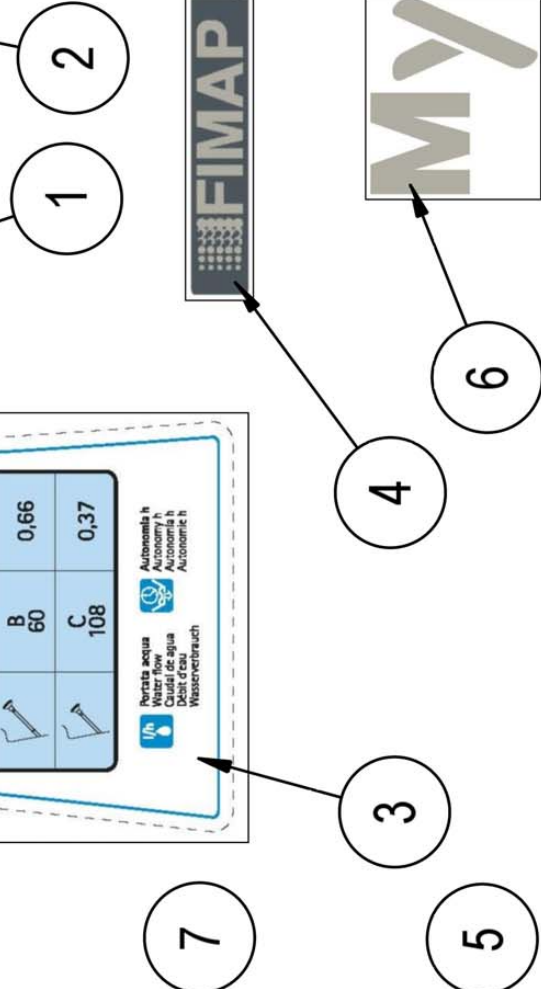

CR-12 GRUPPO ETICHETTE MY50 E

DECAL ASSEMBLY
 GROUPE ETIQUETTE
 SCHILDGRUPPE
 GRUPO ETIQUETA

POS	CODICE	Q.TÀ	DESCRIZIONE	DENOMINATION	DESCRIPTION	BENENNUNG	DESCRIPCION
1	433742	1	ETICHETTA CRUSCOTTO	LABEL PANEL	ÉTIQUETTE PANEL	BESCHRIFTUNGSFELD	ETIQUETA DE PANEL
2	433740	1	ETICHETTA DISGIUNTORE SPAZZOLA	LABEL BRUSH CIRCUIT BREAKER	LABEL BROUSSE COUPE CIRCUIT	LABEL BRUSH SCHALTER	ETIQUETA DE CEPILLO CORTACIRCUITOS
3	434290	1	ETICHETTA REGOLAZ. ACQUA RUBINETTO	LABEL CONTROL VALVE	ETIQUETTE DE RÉGULATION DE VANNE	LABEL VENTIL	ETIQUETA DE CONTROL DE VALVULA
4	436495	2	ETICHETTA SCRITTA RILIEVO FIMAP	LABEL MAJOR WRITTEN FIMAP	MAJOR ÉCRITE FIMAP	LABEL MAJOR SCHRIFTLICHE FIMAP	ETIQUETA DE MAYORES ESCRITA FIMAP
5	437448	1	ETICHETTA FRONTALE LOGO FIMAP 2013	LABEL FRONT LOGO FIMAP	ÉTIQUETTE FRONT LOGO FIMAP	LABEL FRONT LOGO FIMAP	ETIQUETA FRONTAL LOGO FIMAP
6	437528	2	ETICHETTA LATERALE My 2013	LABEL SIDE	ÉTIQUETTE SIDE	ETIKETTENSEITE	ETIQUETA DE LADO
7	437560	1	ETICHETTA AVVERTENZE	WARNING LABEL	ÉTIQUETTE AVERTISSEMENT	WARNHINWEIS	ETIQUETA DE ADVERTENCIA

NOTE

A large rectangular area with a light gray background and horizontal lines, intended for taking notes.



FIMAP S.p.A. - Via Invalidi del Lavoro, 1 - 37059 S. Maria di Zevio - Verona - Italy
Tel. +39 045 6060411 - Fax +39 045 6060417 - E-mail: fimap@fimap.com
www.fimap.com